

City of Minneapolis

PARKLET APPLICATION MANUAL AND GUIDANCE

March 2025



About This Manual

The City of Minneapolis Parklet Application Manual is intended to guide applicants through the process and procedures for applying for a parklet. It provides a comprehensive overview of the program, policies, procedures, criteria and guidelines for creating parklets in the City right-of-way. Business owners, property owners, and other potential applicants are encouraged to read the manual prior to the application process.

Street Cafe applicants should use this manual for guidance and visuals only.

The Minneapolis Parklet Manual was created by the City of Minneapolis Departments of Community Planning and Economic Development and Public Works.

For more information on the parklet program please contact:

Parklet Program Manager
Public Works
Parklets@minneapolismn.gov

For more information on the street cafe program please contact:

Craig Eliason
Community Planning and Economic Development
Craig.Eliason@minneapolismn.gov

Public Works

505 4th Avenue South
RM 410
Minneapolis, MN 55415

Community Planning and Economic Development

505 4th Avenue South
RM 220
Minneapolis, MN 55415



CONTENTS



Parklet Overview
Program Goals
Roles and Responsibilities



Site Selection
Minimum Requirements
Planning



Accessibility Requirements
Design Guidelines
Materials



Implementation Overview
Project Timeline
FAQ



Eligibility Checklist
Parklet Application
Maintenance Letter
Maintenance Checklist



This page intentionally left blank

CITY OF MINNEAPOLIS GOALS

Healthy, safe, and connected people

The people of Minneapolis to be socially connected, healthy, and safe

Healthy, sustainable, and diverse economy

Minneapolis to remain the economic center of the regional with a healthy, sustainable, and diverse economy

High-quality physical environment

Minneapolis has a high-quality and distinctive physical environment in all parts of the City

Complete Neighborhoods

Minneapolis residents to have access to employment, retail services, healthy food, parks, and other daily needs via walking, biking, and public transit



Parklet on Bloomington Ave S , Minneapolis Photo: Mariano Espinoza



ABOUT

OTHER

6

DIAMOND

n/Juxtamps

JXTA
JUXTAPOSITION ARTS

JXTA
JUXTAPOSITION ARTS

Jxta

Juxtaposition

JXTA
JUXTAPOSITION ARTS

JXTA
JUXTAPOSITION ARTS





Parklet on Emerson in North Minneapolis

ABOUT

About This Manual

The City of Minneapolis Parklet Application Manual is intended to guide applicants through the process and procedures for applying to install a parklet. It provides a comprehensive overview of the program, policies, procedures, criteria and guidelines for creating parklets in the City right-of-way. Business owners, property owners, and other potential applicants are encouraged to read the manual prior to the application process.

About Parklets

Parklets are an innovative and cost effective way to add public gathering space to public streets. Parklets are streetscape enhancements, providing an economical solution for increased public open space. Parklets provide amenities like seating, plantings, bike parking and public art. While parklets are typically funded and maintained by neighboring businesses, residents and community organizations, they are publicly accessible and open to all. Parklets are located in the parking lane adjacent to the curb designed as an extension of the sidewalk. Advertising and other commercial activities are not permitted in the parklet.

Parklets Should

Respond to the local surroundings and conditions

Respect accessibility and users of the street environment

Use durable quality materials

Engage the community and generate interest in the public realm



PARKLET PROGRAM

Purpose

Parklets are seasonal public spaces that make the city more livable and walkable. They add space to our streets where people can gather, relax and interact. This program enables and empowers community groups and businesses to transform under utilized street space into vibrant public spaces that are accessible and open to all.

Program Goals

The goal of the parklet program is to make the City more livable, walkable, and beautiful. This program is a step towards the enhancement of the public realm using new tools and techniques.

Program Benefits

- *Make the city more liveable, walkable, and beautiful*
- *Transform underutilized street space into vibrant public space*
- *Support local business communities by creating inviting spaces for community members*
- *Create space for people and community interaction*



Parklet on Emerson Ave. N., Minneapolis

ROLES AND RESPONSIBILITIES

Program Elements

City-owned parklets

- The City owns 3 parklets which community groups or businesses can host for a season. Hosts as selected through a competitive application process. City-owned parklets are public spaces that are accessible and open to all. Advertising and other commercial activities are not permitted in City-owned Parklets.

Community parklets

- Community groups or businesses can design and create their own parklet space following the City's Parklet Manual. All parklets must be accessible and open to all. Advertising and other commercial activities are not permitted in parklets.

Street Cafes

- Businesses can design and create their own space following the City's Parklet Manual and Street Cafe Manual. Street cafes function as an extension of a business and are permitted to allow seating for restaurant customers and are not open to the public

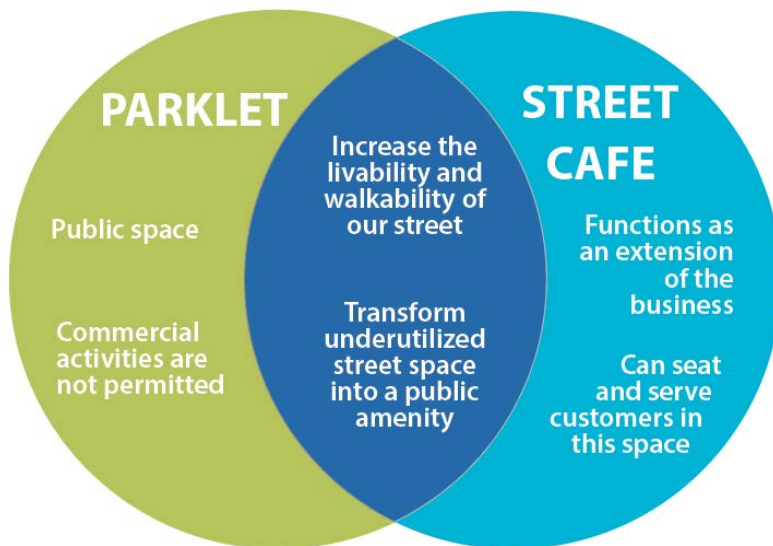
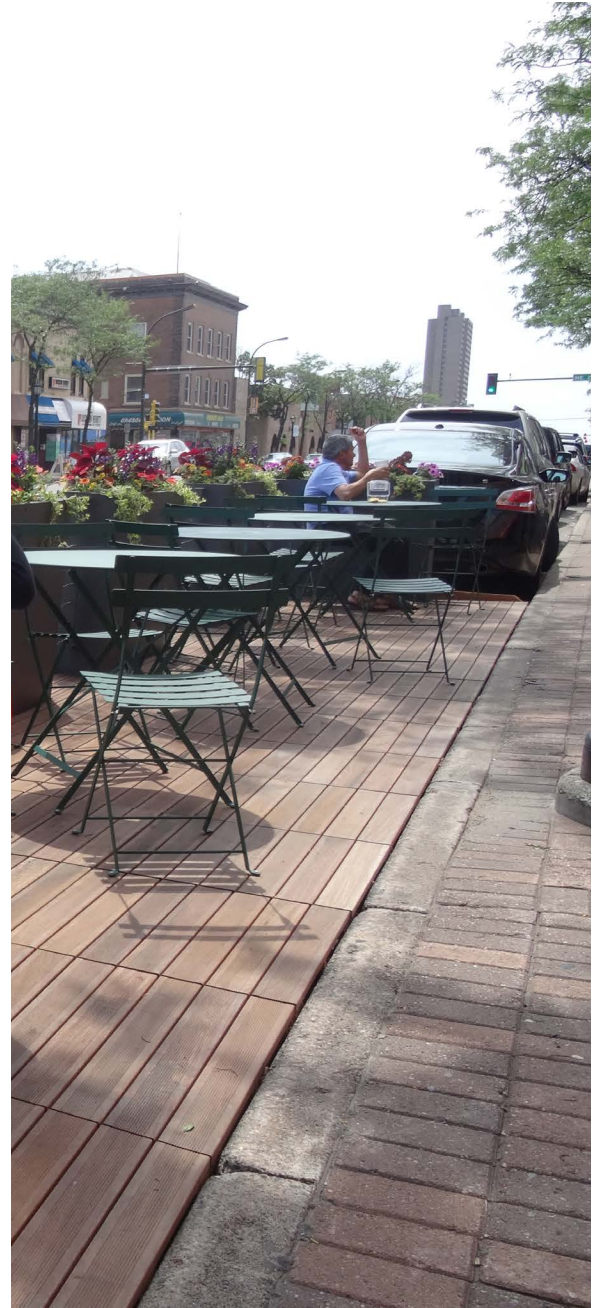

Eligible Applicants

Eligible applicants must have the organizational capacity to conduct outreach with the community and provide daily maintenance. Eligible applicants may be, but are not limited to:

- *Neighborhood organizations*
- *Ground-floor businesses owners*
- *Fronting property owners*
- *Non-profit and community based organizations*
- *Special Service Districts*
- *Others on a case-by-case basis*

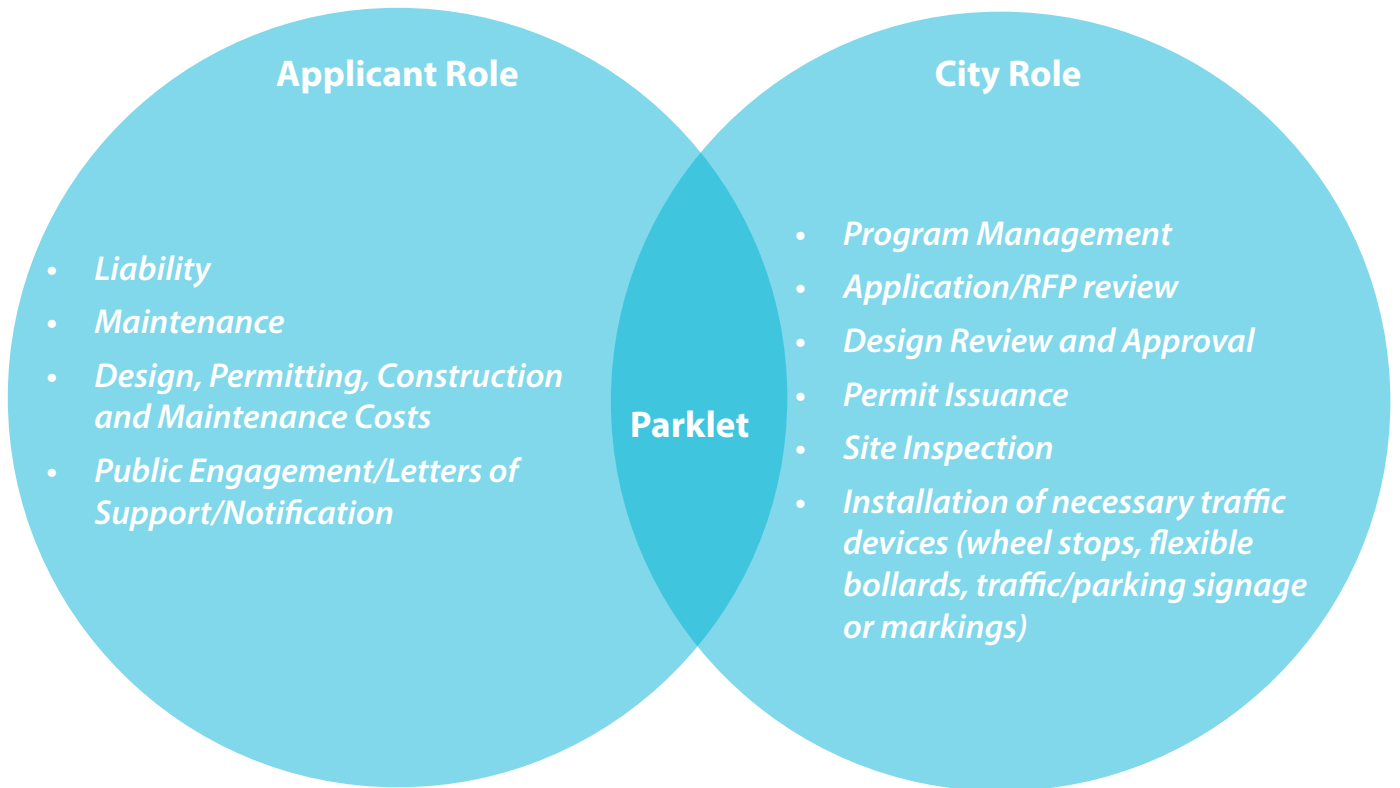

Applicant Responsibilities

Design and installation, capital costs, liability insurance, performance bond (if required), maintenance and upkeep.

Successful applicants will be required to enter into a Memorandum of Understanding (MOU) and receive an Encroachment Permit with the City that commits them to the following:

- *Meet the insurance requirements per [Chapter 95](#) of the City of Minneapolis Code of Ordinances*
- *Keep the parklet and the surrounds clean and clear of debris*
- *Maintain landscape, weeding, watering and pruning*
- *Secure furniture and other movable items as deemed appropriate after business hours*
- *Installation and removal adhering to the dates specified in the Permit and MOU*

Applicants will accept the responsibility for the design, installation, operation, management, maintenance and removal of the parklet. Applicants will maintain the parklet structure and furniture in good repair.



SITE



Parklet on Central Ave NE Minneapolis

SITE SELECTION

Parklet Site Selection

- Should be located in a commercial corridor, community corridor, activity center, commercial node as identified in the Land Use Features map (right)
- Should be located in an unrestricted parking lane, parallel to the curb edge, adjacent to the sidewalk
- Located on streets with traffic speeds 30 mph or less
- Does not block access to public utilities, hydrants, alleys or driveways
- Design does not block existing street drainage patterns
- Parklets must be 15' from catch basins,
- Must be at least one 20' parking space away from the nearest intersection
- Can occupy between one and two parking spaces, length may not exceed 32'
- Cannot be located in a bus stop
- Parklets cannot be located on streets with steep slopes

Unrestricted Parking Lane

An unrestricted parking lane is one that does not have signs restricting the time or type of vehicle that can park there.

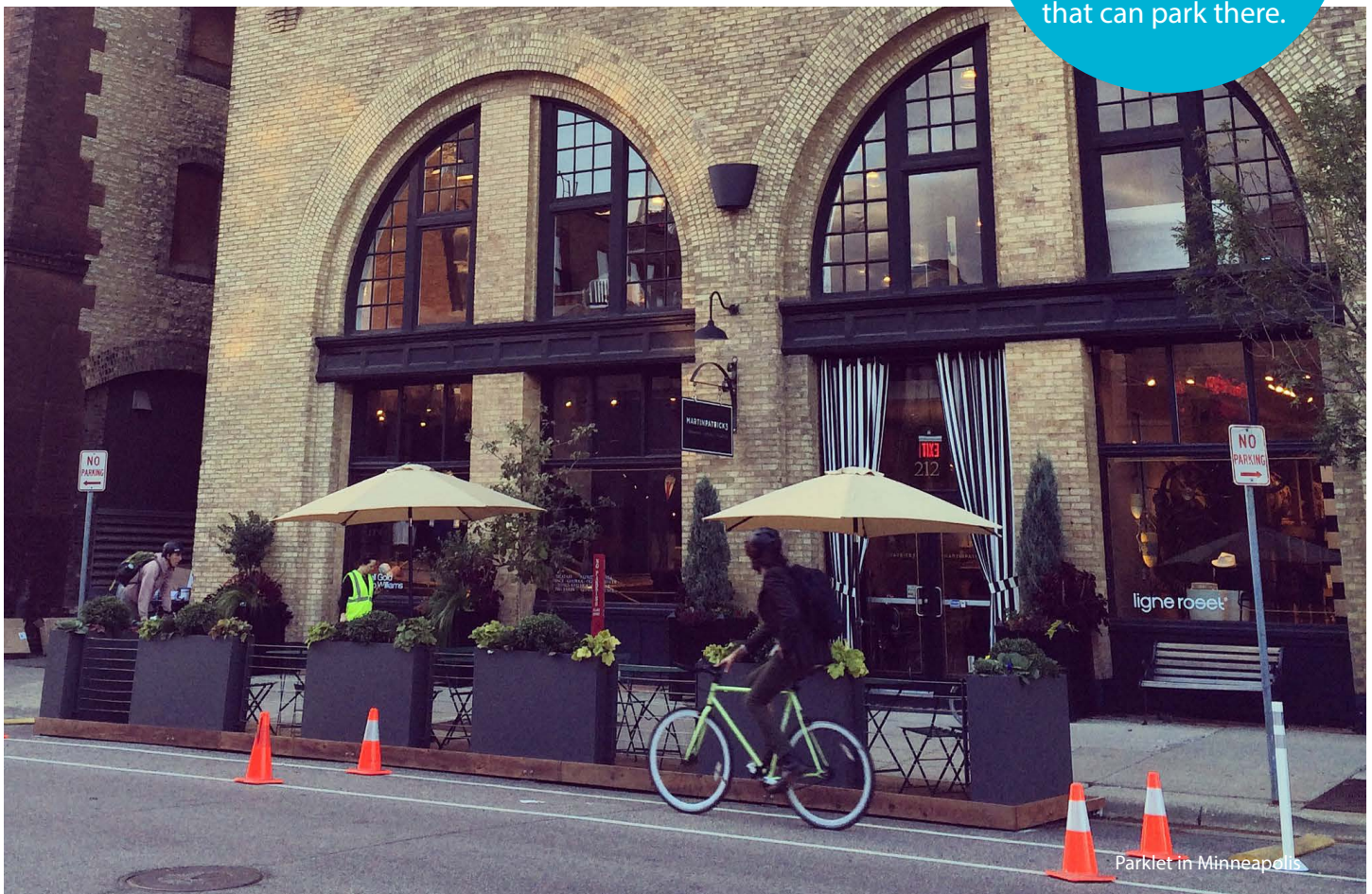

Land Use Features

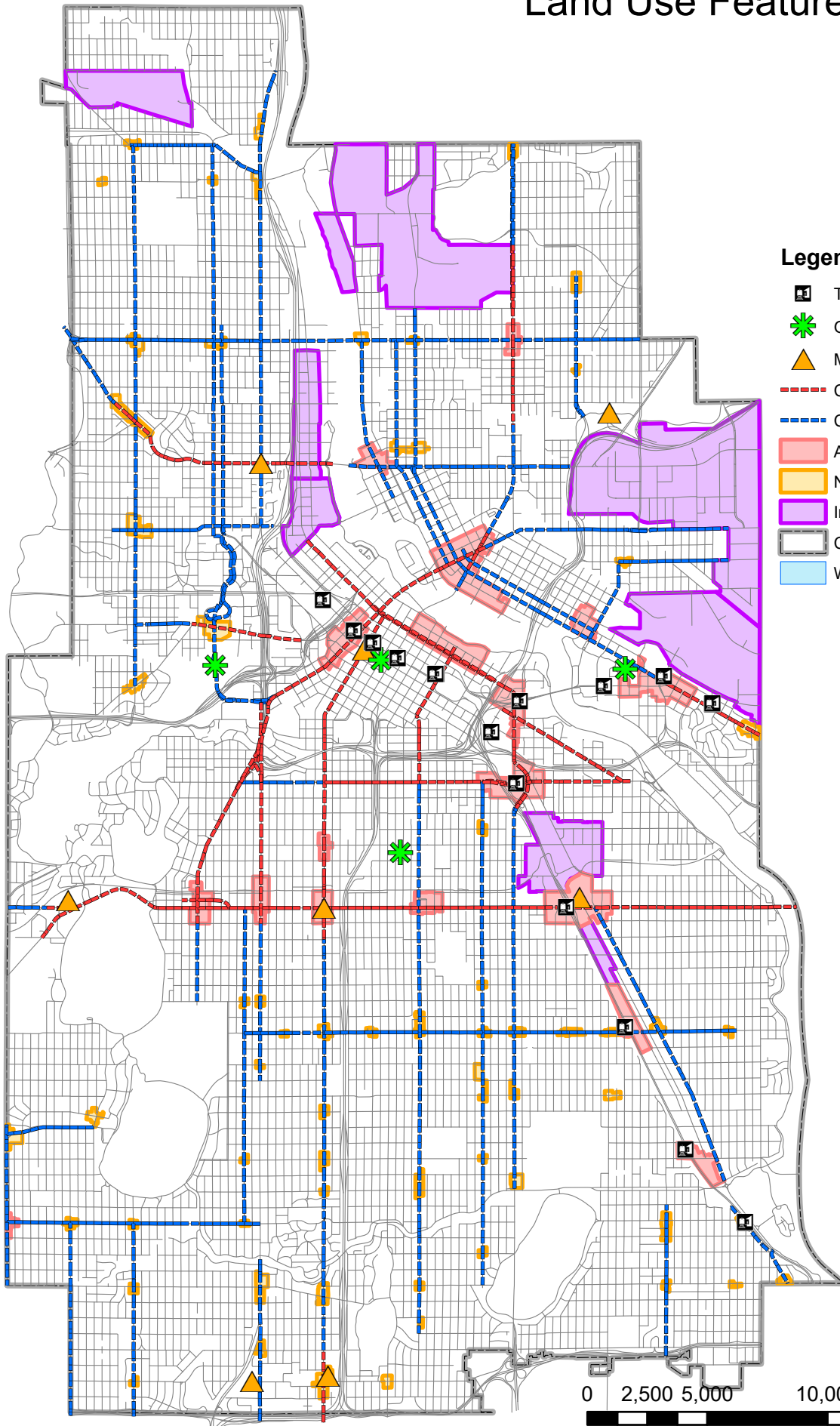

Legend

- Transit Station
- Growth Center
- Major Retail Center
- Commercial Corridor
- Community Corridor
- Activity Center
- Neighborhood Commercial Node
- Industrial Employment District
- City Boundary
- Water



Source:
City of
Minneapolis

Created by:
Minneapolis Community
Planning and Economic
Development Department
Planning Division
Adopted by City Council
October 2, 2009
Amended March 22, 2011
Amended August 16, 2011

0 2,500 5,000 10,000 15,000
Feet

Eligible Parklet Corridors



**ON STREETS WITH
TRAFFIC SPEEDS OF
30 MPH OR LESS**

**LOCATED IN A
COMMERCIAL
CORRIDOR**

**DOES NOT
IMPEDE EXISTING
DRAINAGE
PATTERNS**

REQUIREMENTS

**MUST BE IN AN
UNRESTRICTED
PARKING LANE**

**DO NOT BLOCK
PUBLIC UTILITIES**

PLANNING

Application

1. Applicant must submit online [Confirmation of Eligibility Checklist](#) for the City's consideration prior to application submittal.

As part of the preliminary screening process the City will review proposed sites for:

- Potential conflicts with future street projects
- Traffic patterns
- Street regulations
- Roadway geometry
- Operational considerations

Proposed locations may be turned-down if a streetscape improvement project or an adjacent development project is planned during that calendar year.

APPROVAL

Applications that are deemed eligible for consideration will advance to the full application process.

2. Applicant submits [full parklet application](#), site plan, and support and maintenance letter

Street and curb restoration plan required for installations that fasten to or penetrate the surface of the street.

APPROVAL

3. Applicant submits an [Encroachment Permit Application](#) (Non-Residential fee \$75)
4. Applicant submits a [Lane Use Permit Application](#) (fee currently being waived by the City)

A parklet is approved for one season of use through the encroachment permit process. Applicant is responsible for off-season storage.

APPROVAL

5. Applicant informs City staff of parklet installation as least 1 week prior to installation
 - Installation must occur after Spring street sweeping
 - Removal must occur before Fall street sweeping



BEFORE



Parklet on West 29th Street, Minneapolis

AFTER



Parklet on West 29th Street, Minneapolis

To apply for a parklet, you must submit a completed application, which includes the following information:

- *Site Checklist*
- *Site Plan*
- *Photos of Location*
- *Documentation of Community Support*

An Encroachment Permit is required for any existing or proposed structure or portion thereof that projects onto, under or over any municipal right of way, under the authority outlined in Title 5, Chapter 95, of the City of Minneapolis Code of Ordinances. The Encroachment Permit gives the permit-holder permission to use a specific portion of the right of way until such time as that portion of the right of way is needed by the City of Minneapolis for public purposes. Encroachment Permits are revocable at any time in the interest of public safety.

A parklet is approved for one season of use through the encroachment permit process. Applicant is responsible for off-season storage.

PLANNING

Community Coordination

1. Parklets will launch with the support of the adjacent business/ property partner acting as the parklet sponsor. Proposed sites must meet criteria including traffic considerations, street operations, adjacent property uses and drainage.
2. Applicant is required to present to the neighborhood organization of parklet intent. This will be in the form of a plan and narrative. No formal approval by the neighborhood organization is required, although it is welcome.
3. At the site of the proposed parklet a notice will be installed within the adjacent business' or property's window for a period of two weeks.
4. The parklet will be maintained by the applicant for the duration of the season which will extend to October 31 (weather permitting) at which point the parklet must be removed and stored for the winter by the applicant. Parklets must be removed before fall street sweeping. Please contact parklet program staff to coordinate parklet removal at least one week in advance.

Tip for Success:
The relationship with the fronting business is key for a successful parklet season, consider what type of business it is, and how people on the sidewalk currently interact with the business frontage.





Parklet on Emerson in North Minneapolis



Parklet on Emerson in North Minneapolis



DESIGN



DESIGN

Minimum Requirements include by not limited to:

- ADA Compliant (Accessible from sidewalk, space for wheelchair to turn around)
- Parklets can be at sidewalk level or street level; if at sidewalk level, platform must be flush with sidewalk using slip resistant materials
- Curbside drainage not blocked
- Platform meets intended use
- Publicly accessible with sign indicating public space
- Must include a continuous physical barrier along the three street edges
- Not wider than 6' and no longer than 32'
- Sidewalk facing edge must be open to pedestrians
- Must have vertical elements to be visible to passing vehicles
- Constructed of durable, quality materials
- Public Works will provide wheel stops and flexible bollards for each approved Parklet; additional traffic devices may be required.
- Must maintain clear, unobstructed sightlines to and from the street



ADA Accessibility

- Parklets must be in compliance with The American's with Disabilities Act (ADA) (<http://www.ada.gov/>)
- Please reference The American's with Disabilities Act Accessibility Guidelines, 2010 Standard (ADAAG) (http://www.ada.gov/2010ADASTandards_index.htm)

Wheelchair Turning Space

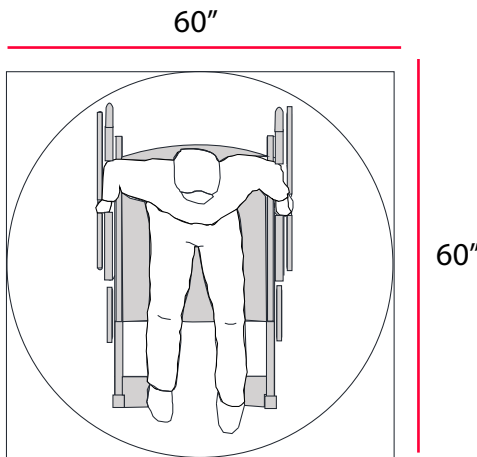

"T" Shaped Turning Space

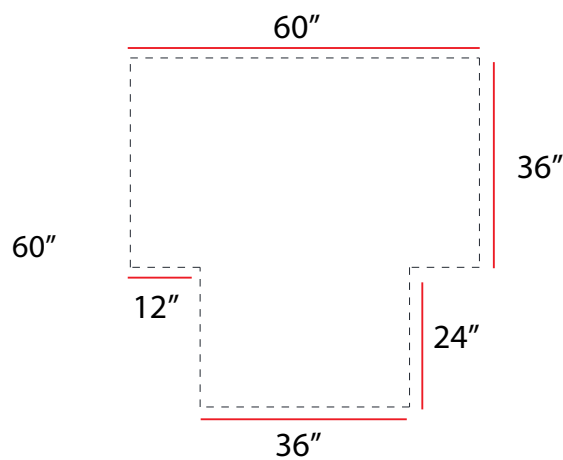

Wheelchair Resting Space

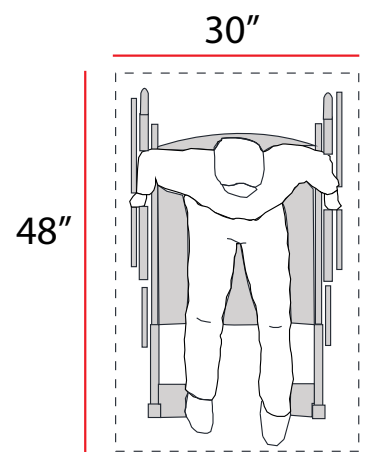

DESIGN

Process

Designing a parklet is an iterative process. Expect to work with the community and the City to come up with multiple versions of the proposed parklet to reach the final design proposal.

Each parklet design has four main components, (seating, enclosure, platform and vegetation) with endless ways for them to be arranged, consider the surrounding conditions and community desires when coming up with parklet proposals.

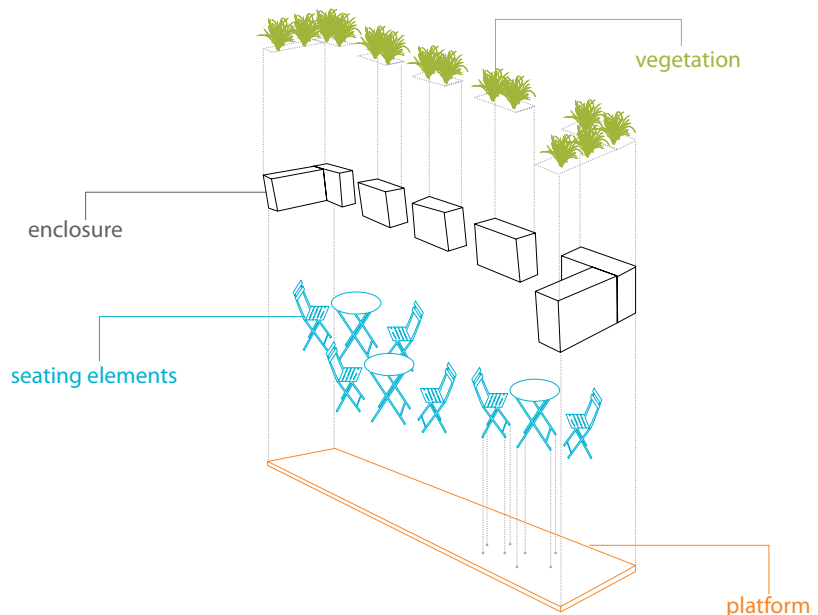
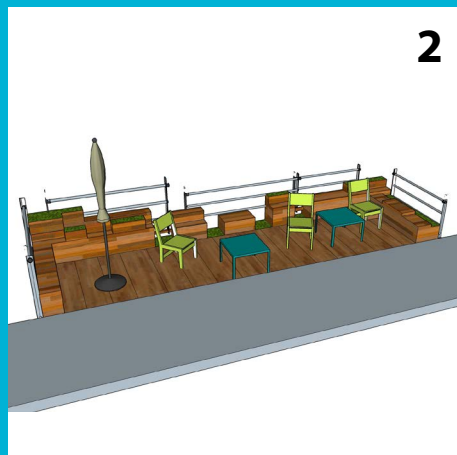

Image: Sarah Sualrz



Past Project Example

The 2015 parklet at Bryant Ave South worked closely with the community and fronting business host to develop a series of designs that led to a final design and a successful parklet.

Images

1. Community engagement for the early design
2. Design concept 1
3. Design concept 2
4. Installed parklet

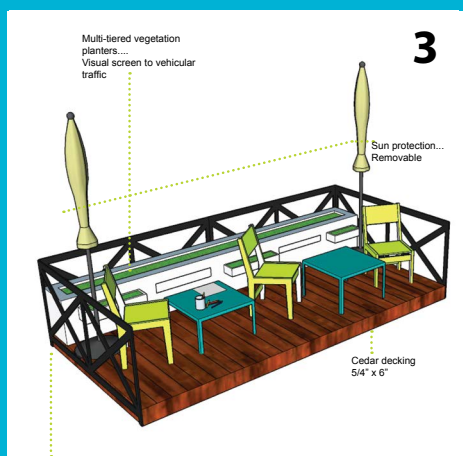

Image: Sarah Sualrz

DESIGN SAFETY

Traffic Control Devices

The City will provide select traffic control devices for each approved parklet location. The City requires each parklet to have two wheel stops and two flexible bollards at minimum.

In addition, parklets in the following locations will be required to have concrete barriers, or similar safety barriers, surrounding the parklet on the three street sides to ensure the safety of users:

- Any parklet (sidewalk or street level) located along City identified [High Injury Streets](#)
- Street level parklets located on [streets with speed limits 25 mph or higher](#) unless there is a buffer in place (e.g. bike lane)

Applicants will be responsible for the installation and removal of these barriers. Failure to comply will result in the removal of the parklet.

Concrete barriers can be purchased or rented on a seasonable basis through third party vendors. Resources for concrete barriers can be found here:

- Safety Signs: (952) 469-6700 or <https://www.safetysigns-mn.com/concrete-barrier>
- Warning Lights: (612) 521-4200 or <https://www.warninglightsmn.com/traffic-control-rental-and-sales>

Applicants may use companies beyond the ones listed above. Please work with City staff if you have any questions regarding this requirement.

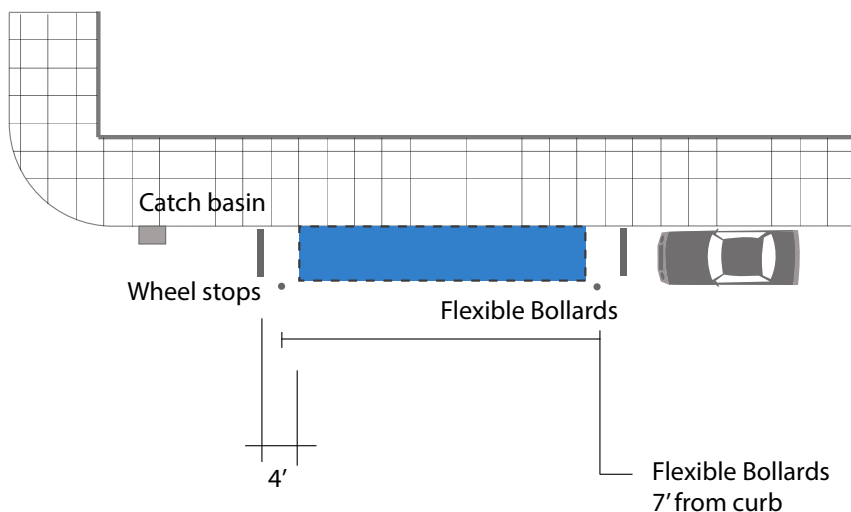

wheel stops
flexible bollards



Image: Parklet in Santa Monica

DESIGN SITING CONSIDERATIONS

Proximity to Bus Stops

Parklets cannot be located within a bus stop zone, marked by the bus stop no parking sign. When proposing a parklet near a bus stop be sure to locate the two signs to help determine parklet placement locations

Typical signs to look for



bus stop sign



bus stop no parking sign

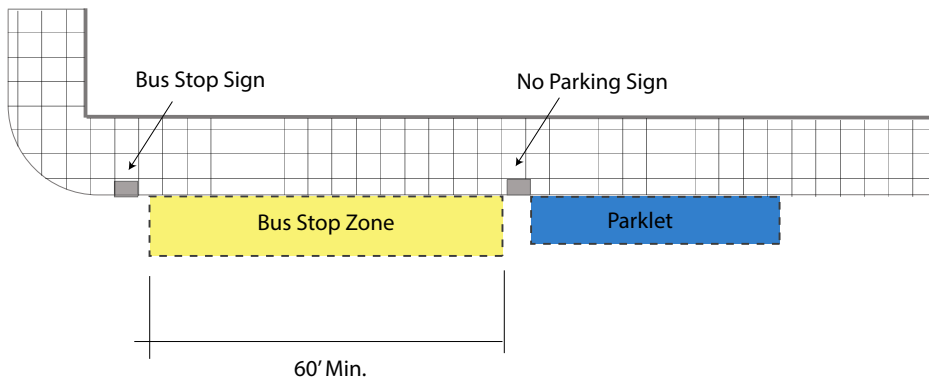

Proximity to Catch basins

Parklets must be located a minimum of 15' from a catch basin.



catch basin

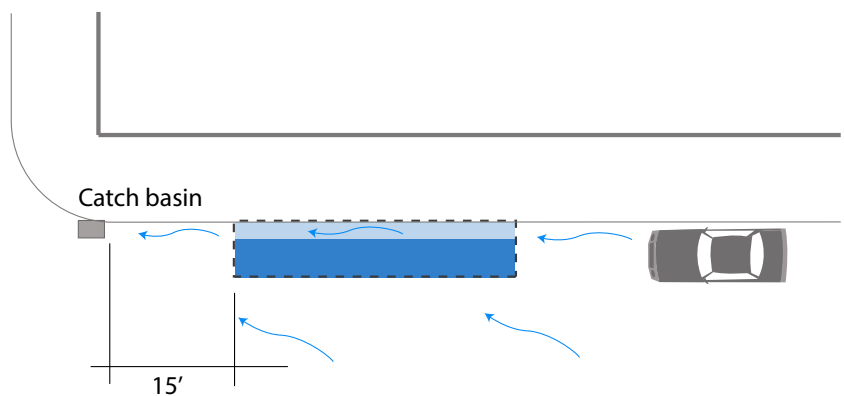

DESIGN SEATING AREA

Seating Area

Parklets are an extension of the sidewalk. They can be at street level or at sidewalk level with the use of a platform. Whether a parklet is located at street level or sidewalk level, they must meet ADA requirements to ensure the space is accessible to all. Both sidewalk level and street level parklets must follow all other guidance in this manual.

Sidewalk Level

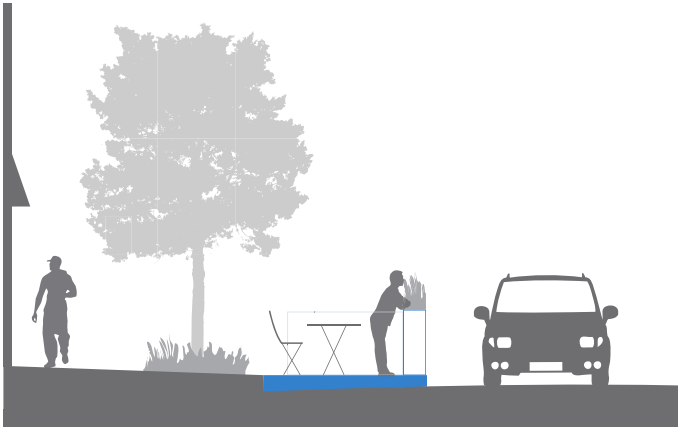

Sidewalk level parklets use a platform that is flush with the sidewalk. This option is generally more accessible to all parklet users as the space can be accessed from anywhere along the platform/sidewalk. Design guidelines and criteria for sidewalk level platforms can be found on pp. 29-31 of this manual.

Street Level

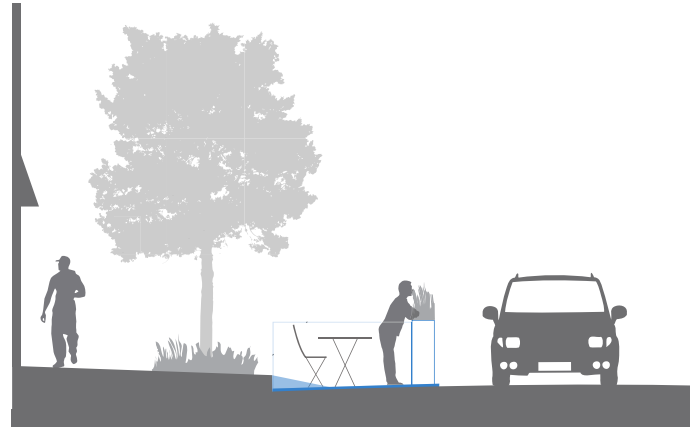

Street level parklets allow applicants to put table and chairs directly on the street without having to build a platform. This option is generally lower cost and can be used to test out the concept of having a parklet before investing in a structure. Street level parklets must have an ADA accessible ramp directly into and out of the parklet at all times. Please follow ADA guidelines outlined on p. 24 and p. 29 of this manual. Enclosures for street level parklets must not block water drainage along the curb.

Public Parklet Sign

Each parklet will also be required to have two public parklet signs attached to the parklet. Public Works staff will evaluate if additional signage is required.

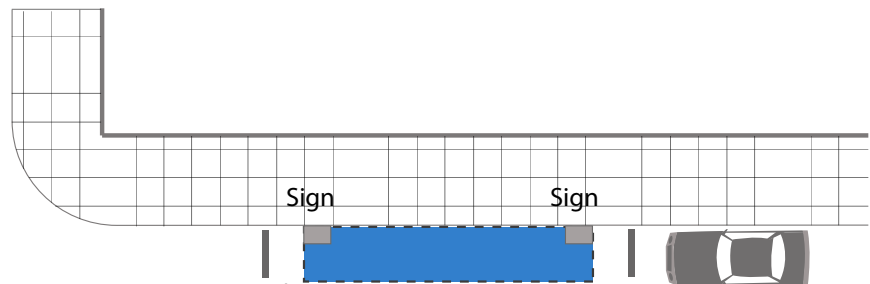

DESIGN STREET LEVEL: ACCESSIBILITY

Accessibility Requirements for Street Level Parklets

All street level parklets must have an ADA accessible curb ramp directly into and out of the seating area at all times. Parklets are public spaces and must be accessible to all people at all times. To meet this requirement, applicants may use temporary or portable ADA curb ramps. Applicants must follow the ADA guidelines outlined in the [Minnesota Temporary Traffic Control Field Manual](#) for temporary curb ramps into the parklet space. Ramp requirements are detailed below:

Temporary Curb Ramp - Parallel to Curb

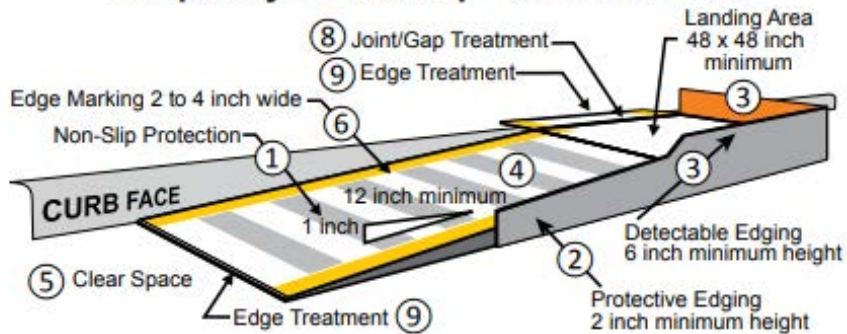

Temporary Curb Ramp - Perpendicular to Curb

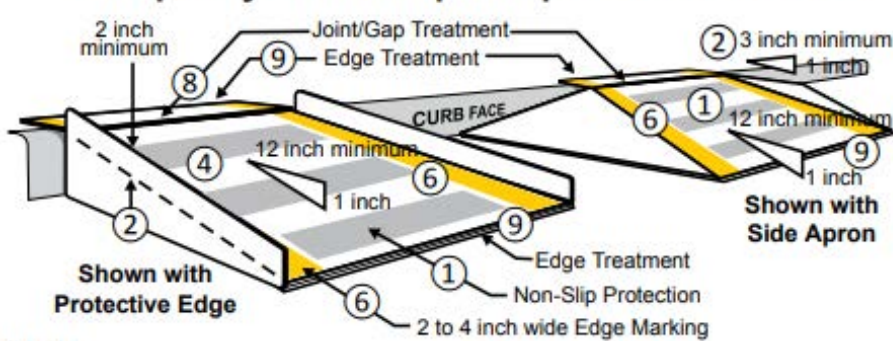

Notes:

1. Curb ramps shall be 48 inches minimum width with a firm, stable, and non-slip surface
2. Protective edging with a 2 inch minimum height shall be installed when the curb ramp or landing platform has a vertical drop of 6 inches of greater or has a side apron slope steeper than 1:3 (33%). Protective edging should be considered when curb ramps or landing platforms have a vertical drop of 3 inches or more
3. Detectable edging with 6 inches minimum height and contrasting color shall be installed on all curb ramp landings where the walkway changes direction (turns)
4. Curb ramps and landings should have a 1:50 (2%) max cross-slope
5. Clear space of 48 x 48 inches minimum shall be provided above and below the curb ramp
6. The curb ramp walkway edge shall be marked with a contrasting color 2 to 4 inch wide marking. The marking is optional where color contrasting edging is used
7. Water flow in the gutter system shall have minimal restriction
8. Lateral joints or gaps between surfaces shall be less than 0.5 inches in width
9. Changes between surface heights should not exceed 0.5 inches. Lateral edges should be vertical up to 0.25 inches high, and beveled at 1:2 between 0.25 inches and 0.5 inches in height

Temporary curb ramps can be purchased or rented on a reasonable basis through third party vendors. Resources for ADA compliant temporary curb ramps can be found here:

- Safety Signs:
(952) 469-6700
<https://www.safetysigns-mn.com/tpar>

Applicants may use vendors beyond the ones listed above.

Please work with City staff if you have any questions regarding this requirement.

DESIGN | SIDEWALK LEVEL: PLATFORM

Platform

For parklets at sidewalk level, a platform is the structural base for the parklet. It supports the weight of the amenities as well as providing the framework for the design. The City strongly encourages working with a design or construction professional to ensure the platform's durability.

The platform may be bolted into the roadway, with the submittal and approval of a restoration plan and bond.

The surface of the platform must be flush with the sidewalk. To comply with accessibility minimums the maximum gap between the curb and parklet can be no larger than one-half inch.

The platform must meet intended use.

Platform Surface Materials

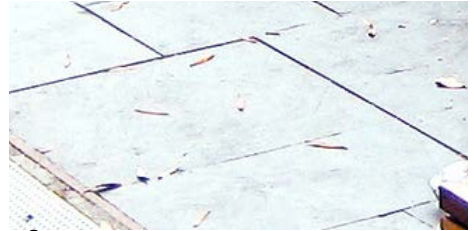

Stone



Wood



Concrete



Synthetic

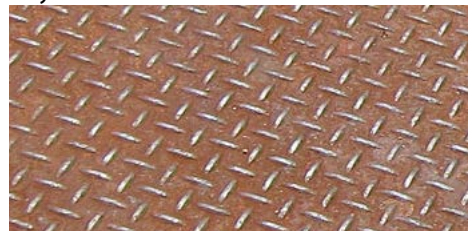

Metal

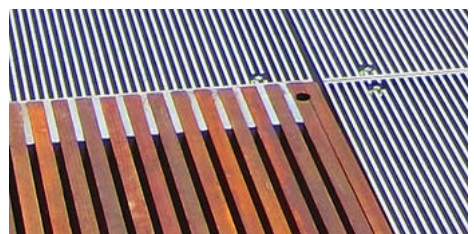

Combination

The platform may not be bolted into the curb or gutter.

Curb

Parklet

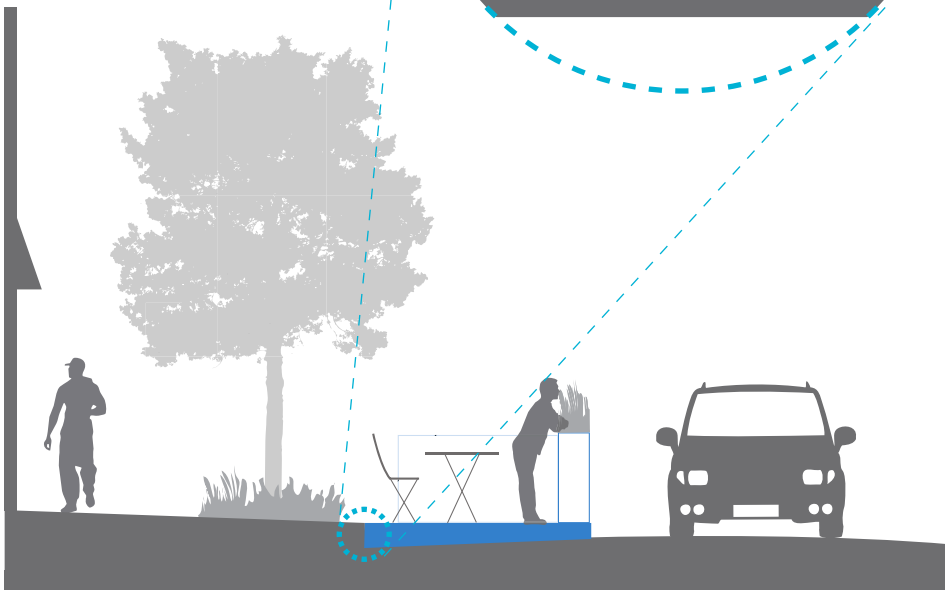

DESIGN | PLATFORM

Materials

The City encourages applicants to consider local and sustainable materials. Additionally, using recycled and reclaimed materials can reduce costs to the applicant. Materials should be selected based on their ability to withstand the impacts of the urban environment and their ability to be maintained. Surfaces should be slip resistant.

Drainage

The parklet must not block the street drainage. The platform must be designed in a manner to accommodate the drainage patterns on the street.

Minneapolis streets are typically crowned at the center of the road forcing water to drain towards the curb. The curb height across the City varies, although a typical curb height is six inches.

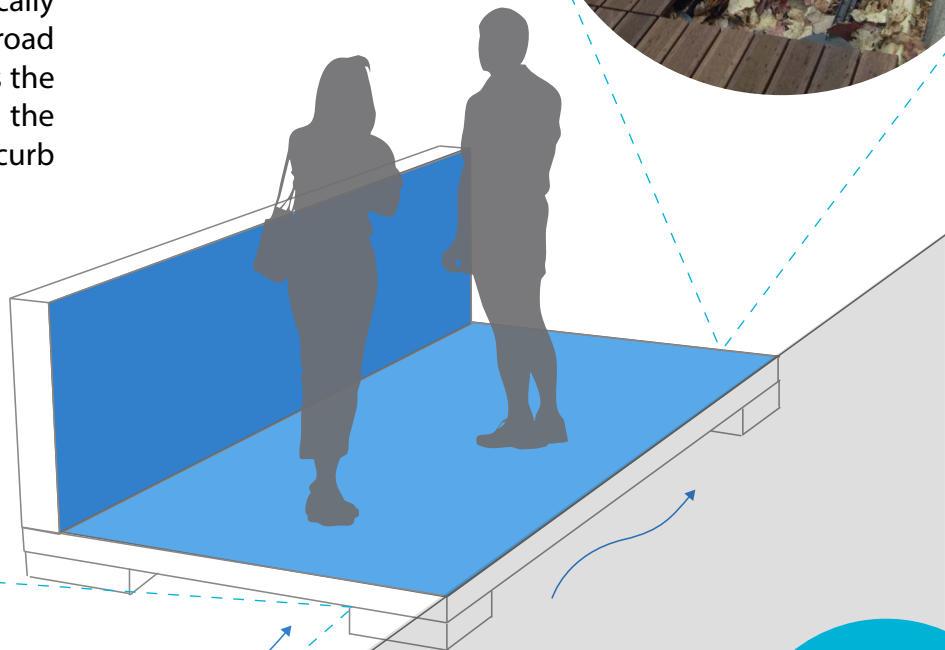
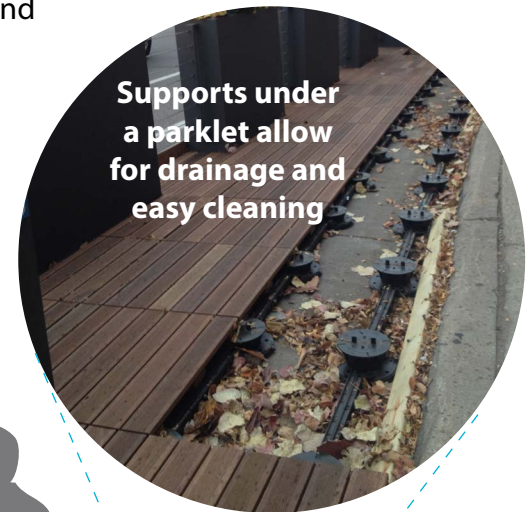

The space beneath the platform must be accessible for cleaning and clearing debris

DESIGN | PLATFORM

“Spanning the Gap”

The Parklet must have a seamless connection to the existing curb to meet ADA requirements. Below are examples of connections found at other parklets.

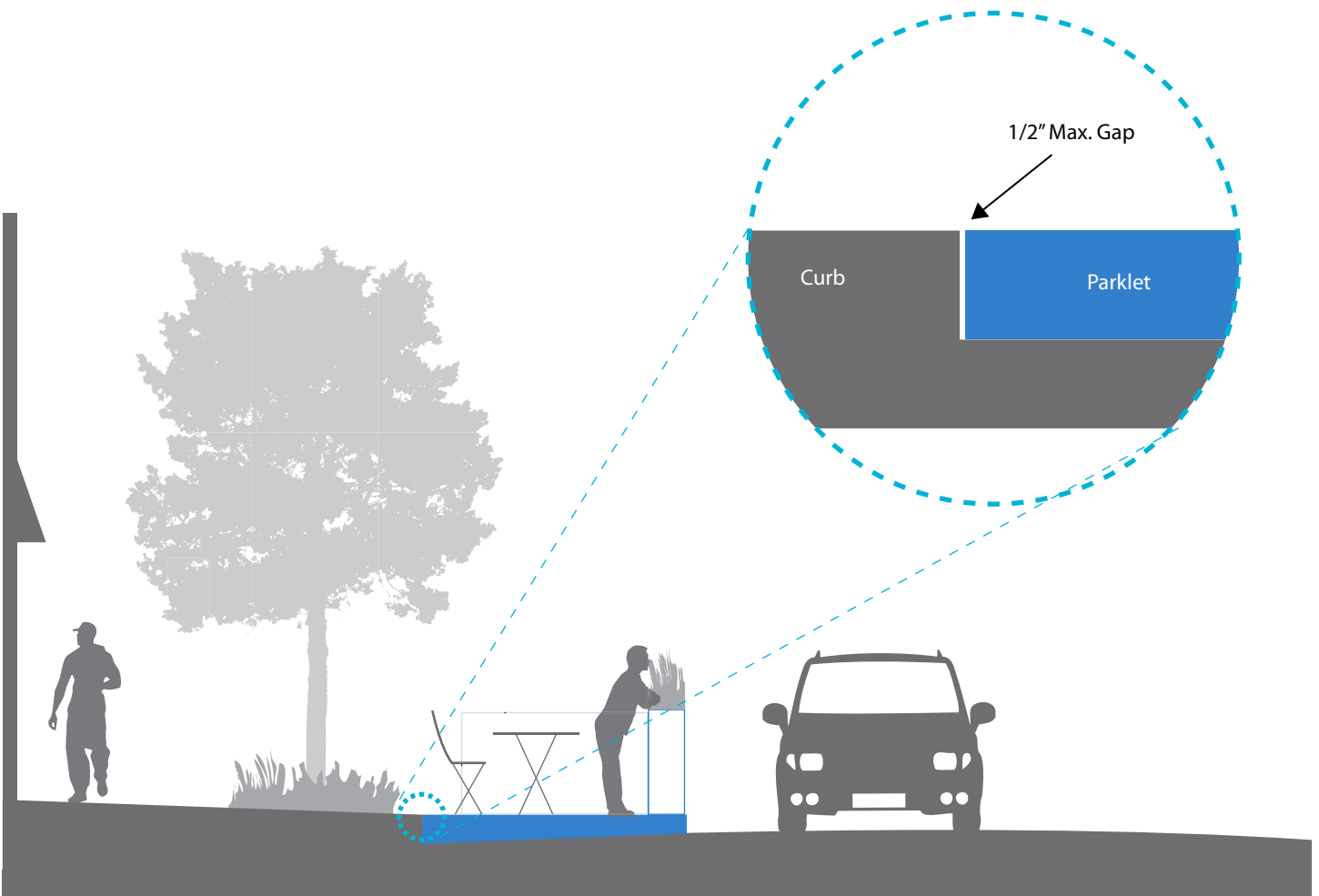
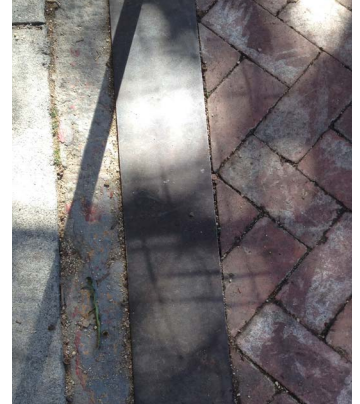

DESIGN ENCLOSURE

Enclosure Materials



Wood



Concrete

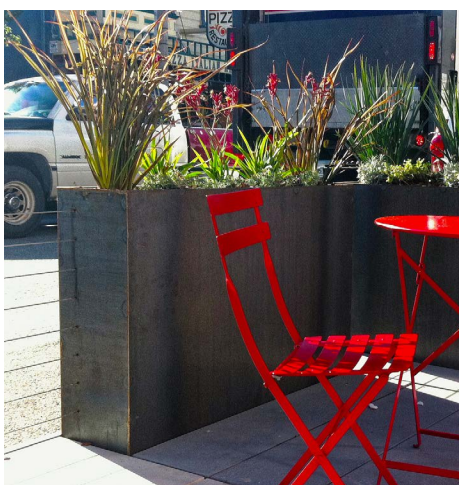

Metal

Enclosure

The enclosure functions to differentiate the parklet edge. The purpose is to create a sense of space while functioning as a buffer between users of the parklet and traffic. The enclosure can be designed creatively with a range of materials while adhering to the basic guidelines below. Overhead elements will be considered on a case-by-case basis, with a minimum vertical clearance of 84".

Materials

The City encourages applicants to consider local and sustainable materials. Additionally, using recycled and reclaimed materials can reduce costs to the applicant. Materials should be selected based on their ability to withstand the impacts of the urban environment and their ability to be maintained.

All enclosures and materials will need to be approved by the City through the application process.

There are a few main features to consider when designing the enclosure. Clear, unobstructed sightlines to and from the street. The enclosure can also function as art panels, planters, or other inventive or creative uses.

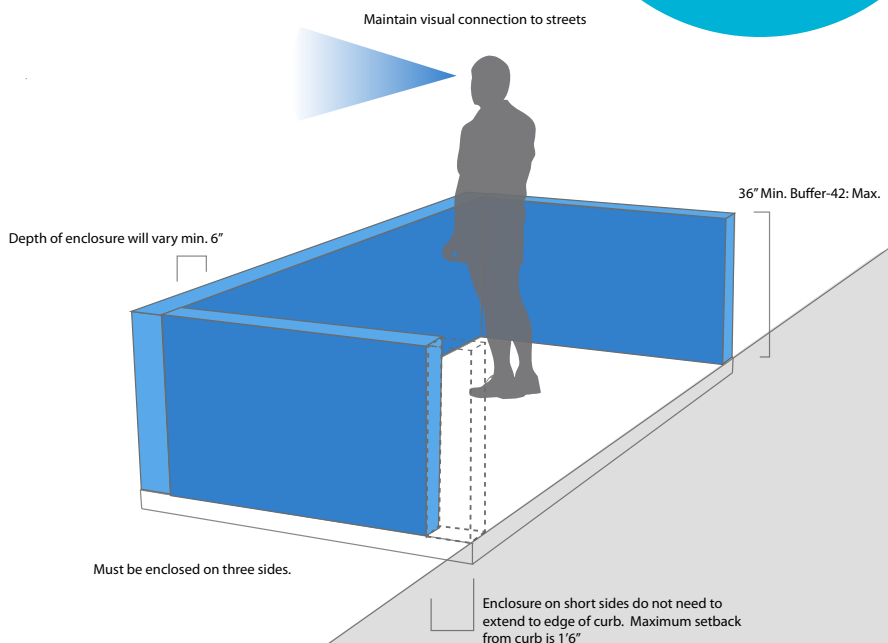

DESIGN SEATING

Seating

The City requires that each parklet include seating or benches. These features encourage gathering, rest and enjoyment of the public space. Seating can be movable or stationary.

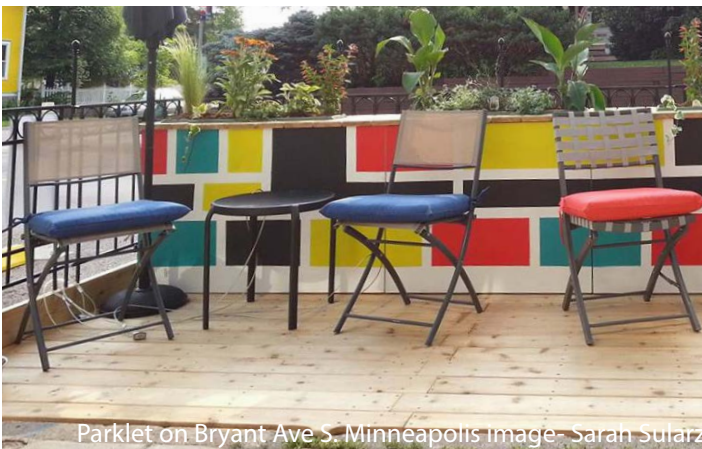

DESIGN | VEGETATION

Vegetation

Vegetation adds character to a parklet and can be used in a range of ways. Vegetation should be selected on hardiness, durability, and interest. Plants are not to be poisonous, noxious or invasive. Plants must be pruned to maintain clear sight lines to and from the street.

Plants can be integrated into the enclosure creating a beautiful buffer.

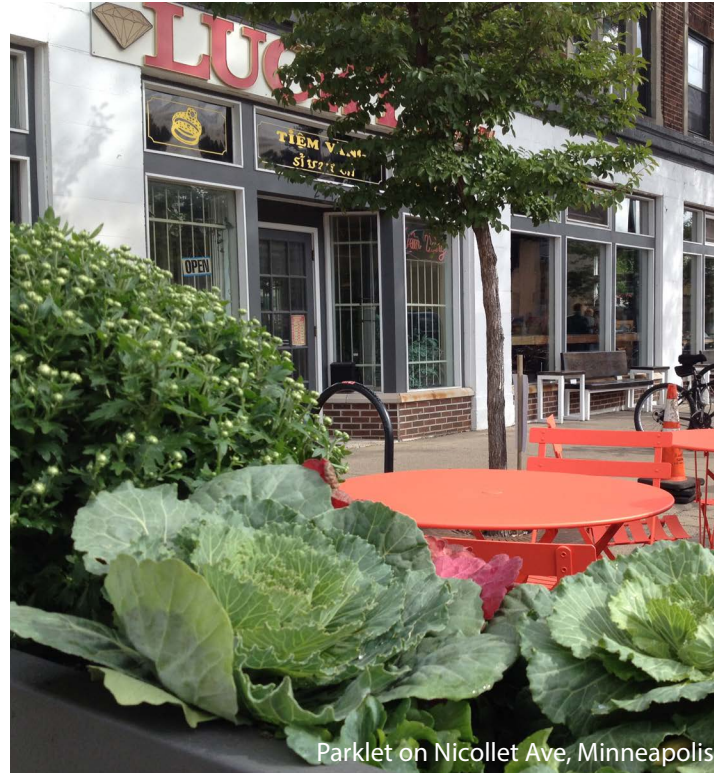

DESIGN | OTHER AMENITIES

Other Amenities

Amenities are the features that create a sense of place in a parklet. These features range from seating, tables, umbrellas, planting, bike racks, to perhaps art. The integration of amenities in a parklet will make the space desirable.

The City invites a range of designs, layouts and forms to be submitted. Minneapolis has a rich artistic heritage and we would encourage that expression on our streets in the designs. Diversity of design can lead to a diversity of use.

Parklets designed by artists or parklets that include public art must be approved by the Arts Commission.

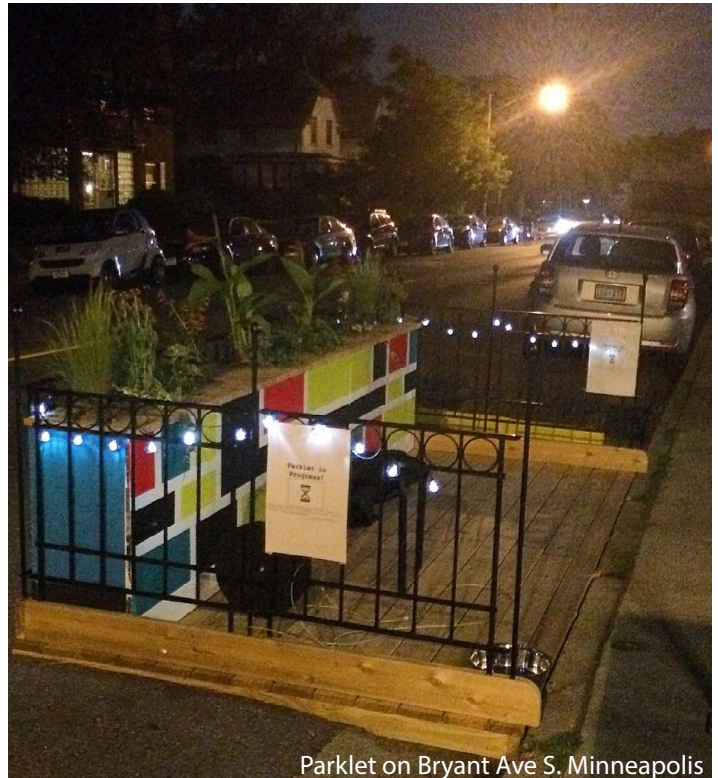

Parklet on Bryant Ave S, Minneapolis



Parklet in San Francisco



Parklet in San Francisco

Integrating bike parking into a parklet is an option. You may also be interested in coordination with the Bike Corral Program.





IMPLEMENT



Parklet on Nicollet Ave, Minneapolis

1

Review all Parklet Program materials

Applicants should review the full Parklet Application Manual. For any questions, please contact parklets@minneapolismn.gov

2

Submit Confirmation of Eligibility Form

[The Confirmation of Eligibility form](#) is used to ensure that the parklet site meets minimum requirements and does not conflict with any infrastructure projects, street maintenance, or adjacent development projects for that year.

- For City-owned parklets, City staff will send out notification of when to apply. The application window for City-owned parklets are generally open for three weeks in March. If you'd like to sign up for notifications about the Parklet Program, please visit the [City's Parklet website](#).
- For community parklets or street cafes, applications are accepted on a rolling basis; however, staff generally review in March/April

City staff will notify applicants if their site is eligible.

3

Eligible applicants proceed to full application

Applicants interested in a City-owned parklet do not need to submit the full application. Hosts for city-owned parklets are selected through a competitive process using the information provided in the Confirmation of Eligibility Form. The top 3 applications will be selected based on the following criteria:

- Equity
- Traffic safety considerations
- Programming plans
- Public space needs in surrounding area
- Community and business support
- Other factors including community group or businesses hours of operations, equitable distribution of parklets across the city

Preference will be given to community groups of businesses who have not hosted a City-owned parklet before.

Community parklets: City staff will review applications based on the following criteria:

- Accessibility
- Property owner support
- Capacity to design, construct, maintain, and adherence to the design requirements
- Quality of design proposals

City Staff will notify applicants of approved sites

4

Applicant submits final plans

Includes site photos, parklet plans, how parklet will meet ADA requirements

5

Applicant submits all necessary permits and agreements

1. Encroachment Permit - *\$75 fee*
 - Information: <https://www2.minneapolismn.gov/business-services/licenses-permits-inspections/streets-sidewalks-utility/use-city-property-row/>
 - Application: https://www2.minneapolismn.gov/media/content-assets/www2-documents/business/Encroachment-Permit-Application_2-18-21.pdf
2. Lane Use/Obstruction Permit - *permit required but no fee associated at this time*
 - For more information and to apply: <https://www2.minneapolismn.gov/business-services/licenses-permits-inspections/streets-sidewalks-utility/city-lane-use-permits/>

6

Installation

Once all permits are secured and the maintenance agreement is signed and received by the City, the applicant can begin installation of their parklet. It is strongly encouraged that applicants assemble as much of the parklet off site as possible to reduce the amount of time within the right-of-way. Any contractors or subcontractors performing installation and removal must acquire obstruction permits and traffic control approvals via Lane Use Permitting, City of Minneapolis Traffic.

Applicants must notify City staff of their installation at least one week in advance.

7

City inspection

City staff will visit the site either during or right after installation is complete to ensure the parklet is meeting all site and ADA requirements.

8

Activities and Maintenance

Parklets should be activated with events, activities, and amenities throughout the season to attract people and keep the community involved. Parklets will be maintained by the application for the duration of the season

9

Removal

Parklets must be removed prior to fall street sweeping. Applicants must inform City staff one week in advance of removal.



APPLICANTS NOTIFIED OF APPROVED SITES

APPLICANT SUBMITS CONFIRMATION OF ELIGIBILITY FORM

STAFF COMMITTEE REVIEWS SUBMITTED APPLICATIONS

CITY STAFF REVIEWS ELIGIBILITY

APPLICANT SUBMITS FULL APPLICATION



0 MONTHS

1 MONTH

2 MONTHS

TIMELINE

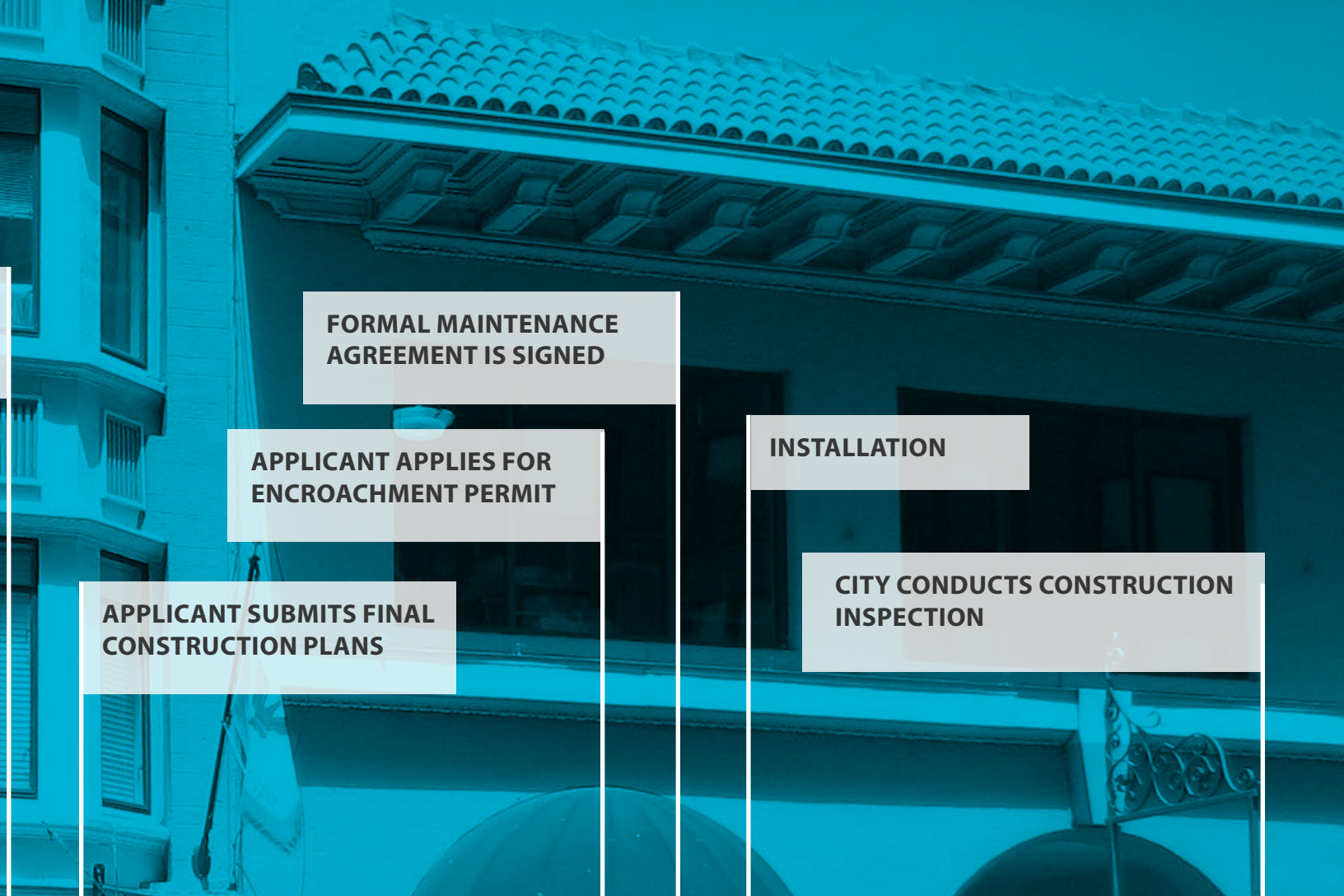

FORMAL MAINTENANCE AGREEMENT IS SIGNED

APPLICANT APPLIES FOR ENCROACHMENT PERMIT

APPLICANT SUBMITS FINAL CONSTRUCTION PLANS

INSTALLATION

CITY CONDUCTS CONSTRUCTION INSPECTION

MONTHS

3 MONTHS

4 MONTHS



MATERIALS & MAINTENANCE

Materials and Construction

Approval required by Public Works. All locations will include flexible bollards and wheel stops as directed by Public Works.

Parklet construction and installation must be overseen by an insured, certified contractor. Elements should be assembled off site to the extent possible, thereby reducing the amount of time of installation in the street.

Operations and Maintenance

The parklet sponsor is responsible for the day-to-day upkeep, including debris removal, garbage clearing, plant pruning and watering and securing furniture at night.

- *Parklets will be open to the public.*
- *Parklets will be installed May-June and will be removed at the end of October of the same year.*
- *Parklets are positioned adjacent to the sidewalk and will be no greater than 32' long by 6' wide.*
- *Parklets require a letter of support from a business/property partner committing to sponsor the parklet for the term of the installation.*
- *Parklet sponsors are responsible for day-to-day management and upkeep, including debris removal, garbage clearing, plant pruning and watering, graffiti removal and securing furniture at night.*

Funding and Insurance Costs Borne by Applicant



ACTIVITIES

Programming a Parklet

One of the most crucial aspects to a successful Parklet is programming. Programming is the planned use of the site in the form of events or performances. Parklets can be successful based on a number of criteria, including siting, adjacent uses, attractiveness of design and of course program. Examples of successful programs in parklets exist across the country and include activities such as:

- Yoga Instruction
- Book Club
- Knitting Circle
- Kids Activities
- Concert
- Pop-up Art Gallery
- Gardening Workshop
- Game Night
- Performance
- Coffee Club

Talk with neighbors and community groups for creative ways to activate your parklet



FAQ

What is a Parklet?

A parklet is a temporary space in the public right-of-way dedicated for public use. It is an expansion of the existing sidewalk designed for the public to relax and enjoy the urban environment.

Are Parklets open to the public?

Yes, parklets are public spaces.

Who pays for a Parklet?

Parklets are funded and maintained by the sponsor group or organization.

Are Parklets permanent or temporary?

Temporary. Parklets are deployed in the spring after street sweeping and are removed in the fall.

Can businesses serve patrons in a Parklet?

Businesses are not allowed to serve customers in a parklet. However, people may buy food or refreshment inside a cafe and then bring it outside to the parklet. If you are interested in serving your customers within a parklet space, you may apply for a Street Cafe.

Where can I put a Parklet?

Parklets are to be located in commercial corridors, community corridors, activity centers, or commercial nodes; be placed within unrestricted parking lanes; not block existing drainage patterns; be located in streets where traffic speeds are 30 mph or less; be located in areas of demonstrated community support; and not block existing critical infrastructure.

Do Parklets have to comply with the Americans with Disabilities Act?

Yes, parklets must be ADA compliant (<http://www.ada.gov/>). Street level parklets must have an ADA compliant ramp down to the street in the seating area (see page 29 for more details). Sidewalk level parklets must have a platform that is level with the curb.

How do I apply for a Parklet?

Follow link here: <https://www2.minneapolismn.gov/government/programs-initiatives/environmental-programs/parklet-program/>

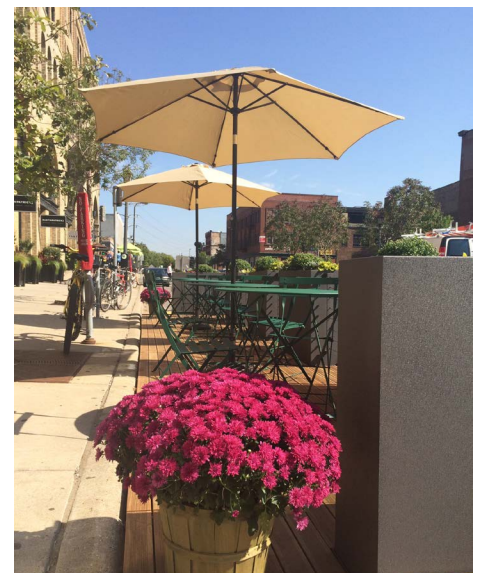
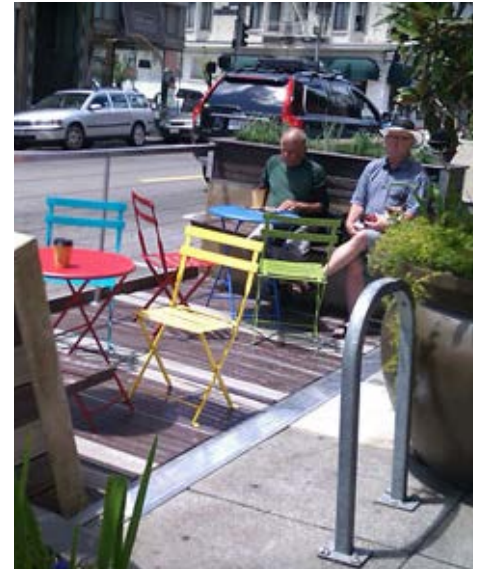

FAQ

Do Parklets require permits?

Yes, parklets require an Encroachment Permit and a Lane Use/Obstruction Permit.

Encroachment Permit - \$75 fee

- Information: <https://www2.minneapolismn.gov/business-services/licenses-permits-inspections/streets-sidewalks-utility/use-city-property-row/>
- Application: https://www2.minneapolismn.gov/media/content-assets/www2-documents/business/Encroachment-Permit-Application_2-18-21.pdf

Lane Use/Obstruction Permit - permit required but fees are waived for parklets

- For more information and how to apply: <https://www2.minneapolismn.gov/business-services/licenses-permits-inspections/streets-sidewalks-utility/city-lane-use-permits/>

Do I have to pay for meter hooding fees if my parklet is in a metered parking space(s)?

The City is currently waiving all meter hooding fees for parklets.

Can Parklets be forcibly removed?

Parklets may need to be temporarily or permanently removed under certain circumstances. The City reserves the right to remove part or all of the parklet for street improvements, utility work, emergencies, violation of the agreement and/or permit or other outstanding circumstances deemed necessary by the City.







Parklet on Bryant Ave S, Minneapolis image- Sarah Sularz

EXAMPLE FORMS

Applicant Details

Applicant Name *

First and last name of the person who will be the primary point of contact

Applicant Email *

A valid and reachable email where the responses to this application will be sent. **This will be the City's primary mode of contact though this application process.**

Applicant Phone Number *

Organization or Business Details

Business or Organization Name *

Business or Organization Address *

Please indicate the address where the parklet or street cafe would be located. If you are applying for more than one location, please fill one form per location.

Have you previously hosted a parklet or street cafe at this location?

Type of Application *

Please select whether you are applying for a parklet or a street cafe.

Parklets are open, public spaces with no table service.

Street cafes can only be used by the business' patrons, can have table service and are not open to the public.

Parklet Street Cafe

Parklet and Street Cafe location requirements *

Optimal locations for a parklet meet the following requirements:

1. Be located in or near business areas or activity centers
2. Located in an unrestricted parking space (No signs limiting parking, such as *No parking*, or *parking only during specific hours*)
3. Located in a street without a steep slope
4. Is located at least:
 - 20 ft from a bus stop
 - 15 ft from a catch basin (storm water drain)
 - 30 ft from a stop sign
5. Does not block access to public utilities, fire hydrants, alleys or driveways

Does your site meet the requirements above? If you are not sure, please detail your answer.

Select 

Is the desired location in a metered parking space? If So, please enter the meter number(s) *

Yes
 No

Will your parklet or street cafe be at street level or sidewalk level? *

- **Street level** refers to installing the chairs and tables directly on the street where the parking spots are. No raised platform needed.
- **Sidewalk level** refers to a parklet or street cafe installed over a raised platform that brings the entire structure to the same level as the sidewalk.

Each type of installation has its own safety requirements. Select your preferred structure to see specific details.

- Street level
- Sidewalk level (choose this option if you are interested in a city-owned parklet)

Neighborhood support letters *

Neighborhood support is an integral part of a successful parklet. Please provide letter(s) of support from neighboring businesses or organizations towards your application.

Attached files can be PDF, Microsoft Word, or image files (for scanned documents)

Drag and drop files here or [browse files](#)

The City does not provide design services, however if you have questions about how to get started contact us at parklets@minneapolismn.gov

- Send me a copy of my responses

Submit

Applicant Name *

First and last name of the person who will be the primary point of contact

Applicant Email *

A valid and reachable email where the responses to this application will be sent. **This will be the City's primary mode of contact though this application process.**

Applicant Phone Number *

Location Details

Proposed Parklet Location *

Address of primary business front where the parklet or street cafe will be located.

Ward Number *

Select ward number where the parklet will be located. Council Member names added for ease of use.

Property Owner Name *

Property owner email *

Property owner phone number *

Designer Details *

Please select which of the following options describe your plans for parklet design.

Target Installation Date *

Indicate the approximate desired installation date for your parklet

Materials Upload *

Please upload the following **mandatory** files, labeled as follows:

1. Site plan - *HappyParklet_SitePlan*
2. Site photos - *HappyParklet_Photo_01_Front*
3. Specifications and/or material sheets - *HappyParklet_Specs_01*
4. **[For parklet applicants only]** Support and Maintenance Letter, signed by both applicant and property owner - *HappyParklet_SuppLetter*

[See Support and Maintenance letter template here](#)

Drag and drop files here or [browse files](#)

Send me a copy of my responses

Powered by  smartsheet
[Privacy Notice](#) | [Report Abuse](#)



Department of Public Works
505 4th Ave S, Room 410
Minneapolis, MN 55415
Tel 612.673.3000
www.minneapolismn.gov

Jane Smith
The Coffee Shoppe
123 Fake Street
Minneapolis, MN 12345

[DATE]

Kaitlyn Denten
505 4th Ave S, Room 410
Minneapolis, MN 55415

Agreement to Support and Maintain Parklet in the Public Right of Way

Dear Kaitlyn Denten,

On behalf of **The Coffee Shoppe**, we are writing to express our support of our **and/or design** team's proposal to implement a temporary parklet outside **The Coffee Shoppe on Fake St.**

We are enthusiastically in support of the creation of a publicly accessible temporary seating area adjacent to **The Coffee Shoppe**. We recognize that the parklet will be installed immediately adjacent to the curb within the confines of two parking spaces. Furthermore, **The Coffee Shoppe** understands the following:

- The parklet will be installed after Spring street sweeping and removed before Fall street sweeping,
- The parklet will be open to the public,
- The parklet is temporary.

The Coffee Shoppe agrees to keep the parklet free and open to all members of the public, regardless of whether or not they patronize the business or any other businesses nearby. **The Coffee Shoppe** will not provide table service at the parklet. Additionally, we will provide timely tidying as necessary in the parklet to ensure it remains clean and well maintained.

The Coffee Shoppe will notify the City of installation at least one week prior to installation and removal. Further, **The Coffee Shoppe** will be notified at least one day in advance of any changes or modifications which may impact use or operation of the space.

The Coffee Shoppe will be responsible for the day-to-day operation and maintenance of the parklet. This includes, but is not limited to, the removal of debris and garbage, the watering and pruning of plants, securing the movable furniture when **The Coffee Shoppe** is closed, and all other activities indicated in the Daily Care and Upkeep Checklist. **The Coffee Shoppe** has the staff capacity to complete the day-to-day maintenance.

Sincerely,

[signature]
[applicant name]
Owner/Applicant, **The Coffee Shoppe**

[signature]
[property owner name]
Property Owner, **123 Fake St**

*Maintenance Checklist Example***City of Minneapolis Parklet Program
Daily Care and Upkeep Checklist**

- Clean up rubbish within and around the parklet
- Sweep the area in and around the parklet
- Remove debris against the outside edge of the parklet
(Especially at the curb to help maintain free flow of storm water drainage.)
- Water, and maintain plantings
- Place furniture each morning
- Place and open umbrellas, weather permitting (keep an eye on the wind)
- Wipe down tables and chairs as needed
- Take down and secure furniture and umbrellas overnight
- Comments, questions, or concerns?

Please direct community members to provide feedback through 311, by phone or online. You may also forward feedback to parklets@minneapolismn.gov Feedback collected will be used to evaluate the parklet program.



Minneapolis
Public Works

Minneapolis Dept. of Public Works - Right of Way Section
505 4th Ave S Rm 410A
Minneapolis, MN 55415
Office 612-673-3607
Email PwRightofWay@minneapolismn.gov
www.minneapolismn.gov/publicworks/permits

Encroachment Permit Application

Submit completed application in person, by email, or by U.S. Mail to the Public Works Right of Way Section. Application shall be accompanied by a non-refundable application fee payable to the "Minneapolis Finance Department" according to the following schedule:

Residential: \$50 Non-Residential: \$75 Amendment to Existing Permit: \$25 (at the discretion of the Department of Public Works)

Property Information			
Property Owner:			
Property Address:			
Property ID:		Ward:	
Applicant Information			
Name:			
Address:		City:	State:
Phone:		E-mail:	
Applicant Signature:			Date:
Encroachment Description			
Please describe the type of encroachment being requested, and the materials to be used:			

Attach a survey/site plan which shows the details and dimensions of the encroachment. The drawing must show accurate property lines and the location of elements of the right of way, such as streets, sidewalks, boulevards, curbs, curb-cuts, trees, hydrants, lights and signs, bus stops, and utilities. Photos of the site showing current conditions are requested (digital on disk or by email are best).

Revised February 18, 2021