

SLEEVE #	"A" LENGTH
1	15.0 ± 0.06
2	29.88 ± 0.06

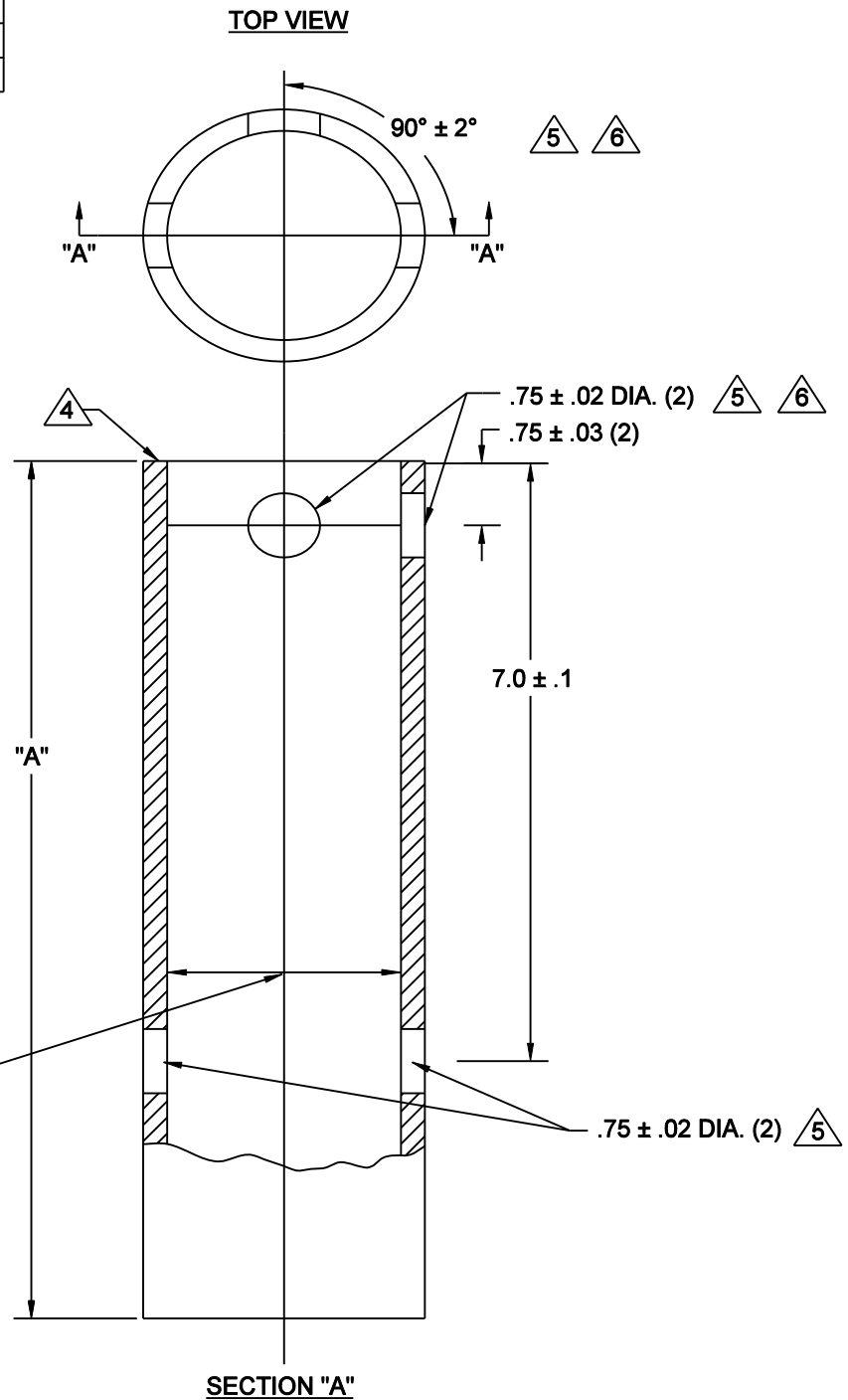

**NOTES:**

- 1 MATERIAL- NPS 2 1/2 HOT DIPPED GALVANIZED STEEL PIPE TYPE E OR F, SCH 40 PER ASTM A53-02.
- 2 ALL DIMENSIONS IN INCHES.
- 3 ZINC COATING SHALL BE FREE FROM EXCESSIVE ROUGHNESS.

- △4 NO CUT-OFF BURR PERMISSABLE -THIS END-.05 MAX. CORNER BREAK PERMITTED.
- △5 NO ORIENTATION OF 2 HOLES AT END TO MID 2 REQ.
- △6 90° APPLIES TO (2) HOLES INDICATED ONLY.

NO SCALE

	<b>MINNEAPOLIS</b> DEPARTMENT OF PUBLIC WORKS		COLLAR - SIGN 2" SIGN POST - SLEEVE	STANDARD PLATE NO. TRAF-5130
	DRAWN: LPK	DATE: 1/1/11		
	APPROVED: DRP	DATE: 1/1/11		