

2" (2 3/8" O.D.) SCHEDULE 10
PIPE X 5" LONG SLIPFITTER
(TYP.)

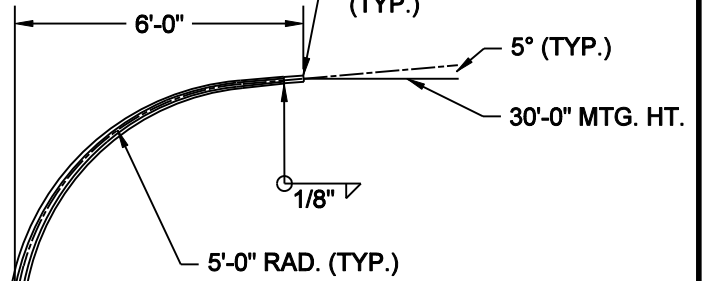

- NOTES:**
1. MATERIAL-HIGH STRENGTH, LOW ALLOY STEEL 50,000 PSI MIN. YIELD, (ASTM A572 OR EQ.) POLE BASE PLATE MATERIAL TO BE 36,000 PSI MIN. YIELD (ASTM A36).
 2. FINISH-EPOXY PRIMER.
 3. FINISH-UPS BROWN THERMO-SET ACRYLIC.

11 GA. X 8.6" X 3.1" X 31'-0"
(230C45-175, 35" COIL)

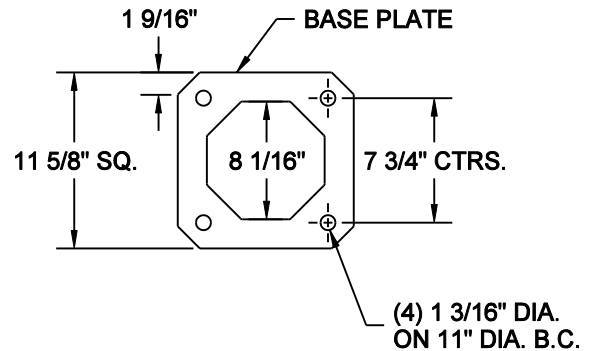
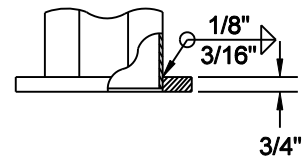
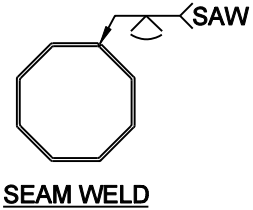

POLE BASE DETAIL

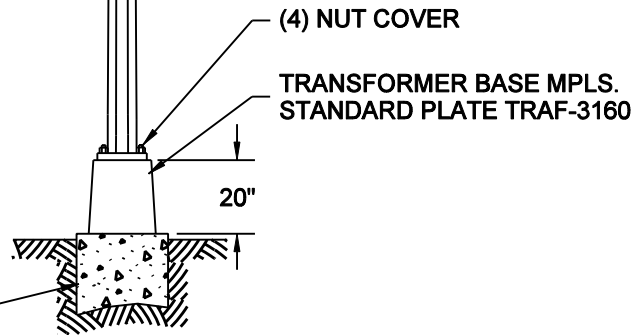

NO SCALE

	MINNEAPOLIS DEPARTMENT OF PUBLIC WORKS		STANDARD - ST. LIGHT 6M-30' STEEL REFERENCE PLATES: TRAF-3072, TRAF-3160	STANDARD PLATE NO. TRAF-3238
	DRAWN: LPK	DATE: 1/1/11		